

LES EVENTUELLES ADAPTATIONS DE GEOMETRIES RELATIVES AUX PROCEDES DE FABRICATION ET LES DEFAUTS D'INJECTION SANS IMPACT FONCTIONNEL SUIVANTS SONT ADMIS ET A L'APPRECIATION DE HELLERMANN TYTON: SEUIL D'INJECTION, BAVURES NON DETACHABLES, DEFAUT MANQUE MATIERE, TRACES ET BAVURES SUR EJECTEURS, DECALAGES DE PLANS DE JOINT, BRULURES ET AUTRES DEFAUTS D'ASPECT.  
THE MANUFACTURING-RELATED GEOMETRY CHANGES AND THE INJECTION DEFECTS WITHOUT FUNCTIONAL IMPACT ARE ADMITTED AND SUBMITTED TO THE APPRECIATION OF HELLERMANN TYTON : INJECTION POINT, NO REMOVABLE FLASH, LACK OF MATERIAL, MARK AND FLASH ON EJECTOR, PARTING LINE OFFSET, BURN AND OTHER DEFAULT ASPECT.

TABLEAU DE RESERVES	RESERVES TABLE
DEVELOPEMENT: DIMENSIONS FINALES ET TOLERANCES APRES ESSAIS ESSAI: *SOUS RESERVE D'ESSAIS PHYSIQUES	DEVELOPMENT: FINAL DIMENSIONS AND TOLERANCE AFTER TEST TEST: *SUBJECT TO PHYSICAL TESTING

MASSE MASS (g)	COULEUR COLOUR	QUANTITE QUANTITY	TENUE AU SERRAGE TENSILE FORCE	MATIERE MATERIAL	NUMERO DE PROJET PROJECT NUMBER	PIECE SEMI-FINIE SEMI-FINISHED PART
2.7	NOIR / BLACK	1	-	PA66 HIRHS	GPN 17-0934	IAHC1T
0.7	NOIR / BLACK	1	-	PA66 HIRHS	GPN 10-0016	ICR
1.4	NOIR / BLACK	1	225N	PA66	GPN 12-0123	T50R

TABLEAU DES MATIERES / MATERIAL TABLE

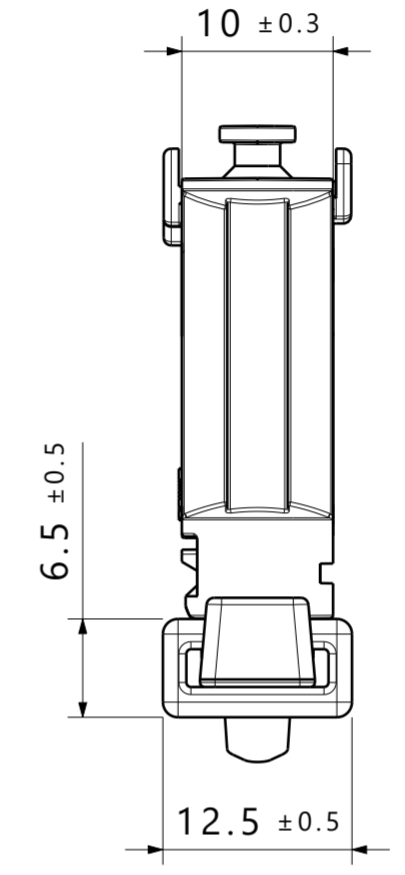
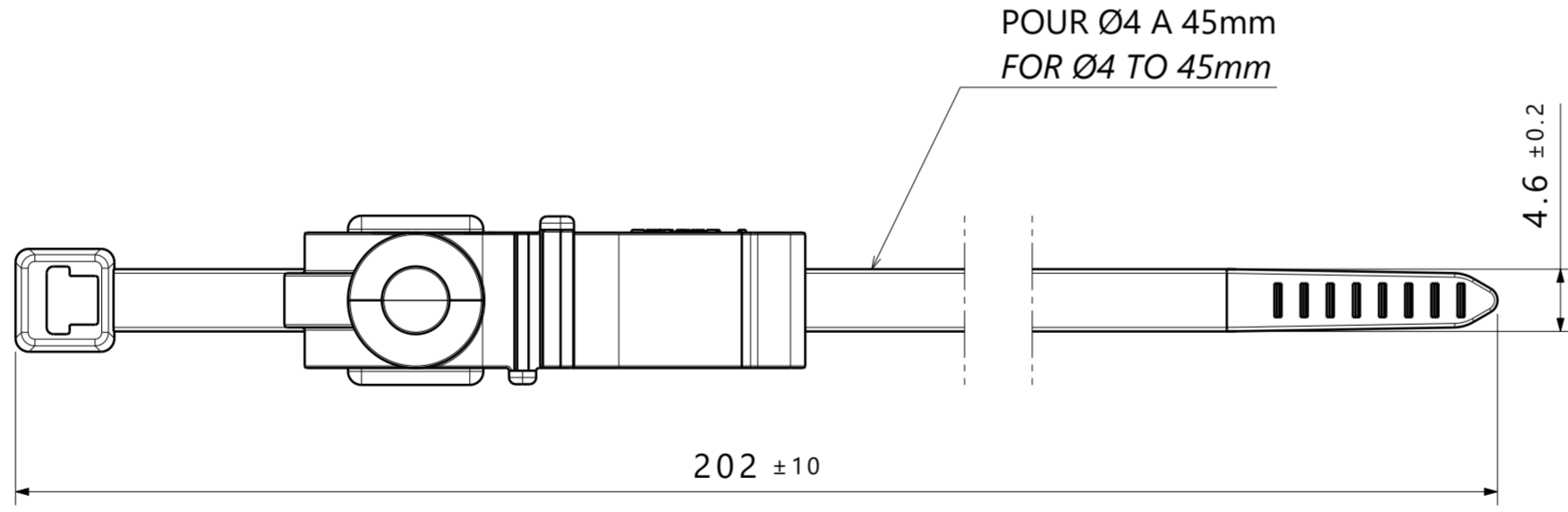
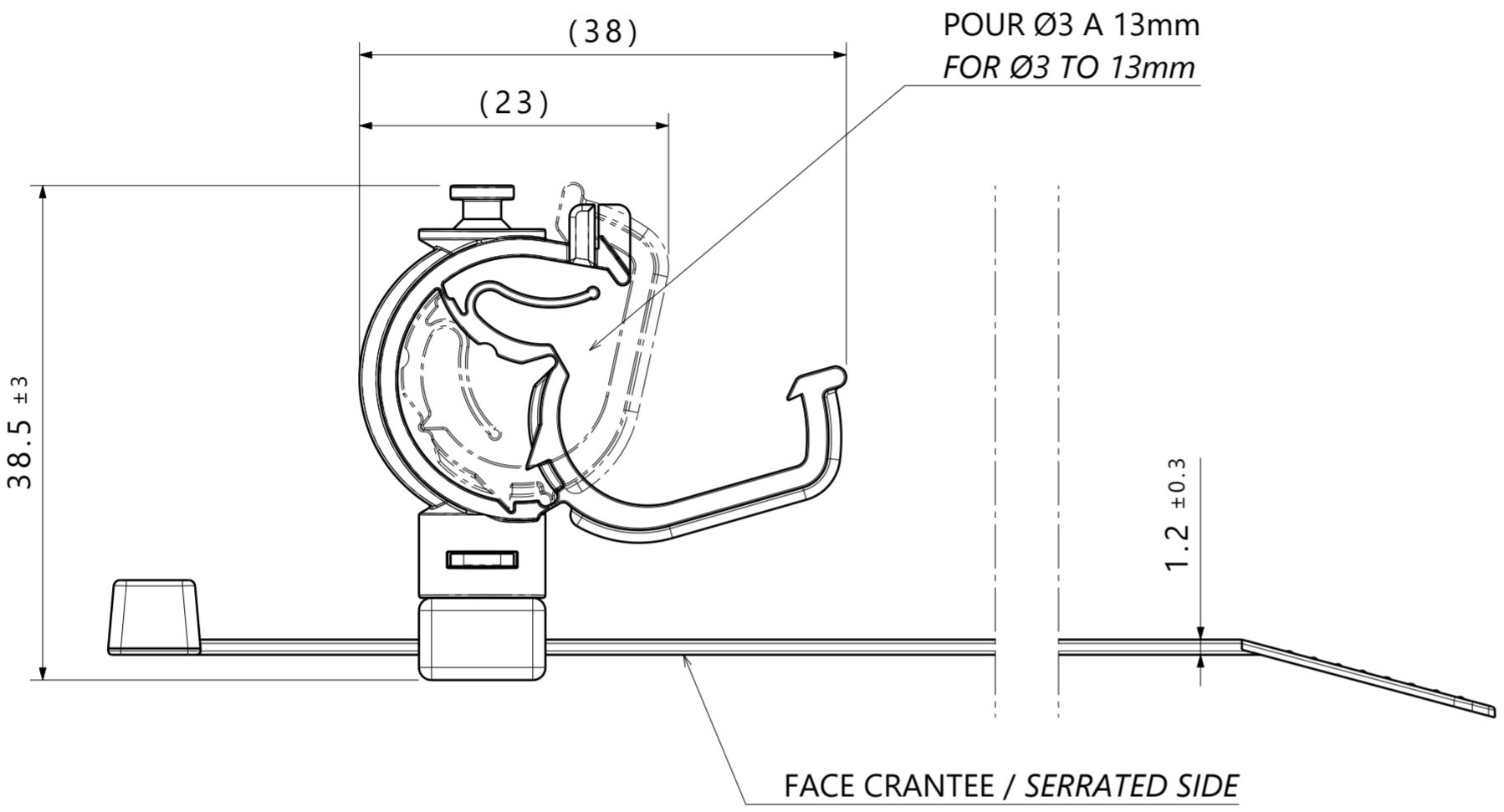

ECHELLE / SCALE : 1:1

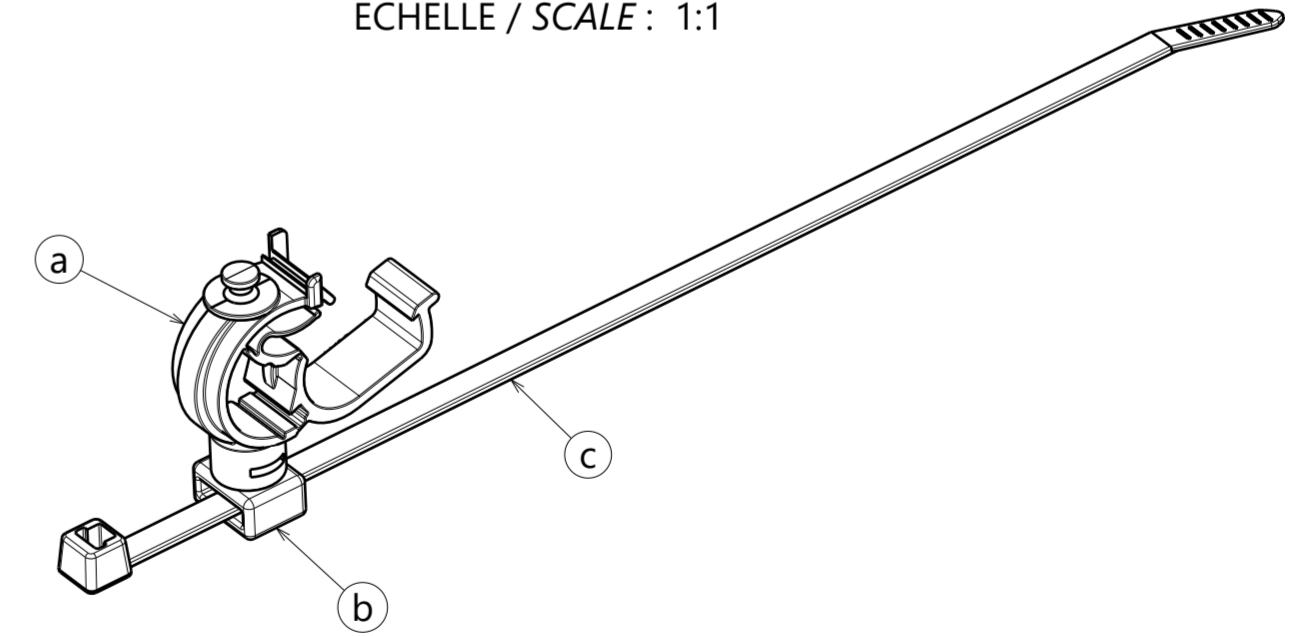

ROTATION LIBRE ENTRE CLIP A ET COLLIER C  
FREE ROTATION BETWEEN CLAMP A AND CABLE TIE C

TOLERANCES DIMENSION WITHOUT TOLERANCES						
ANGLE	≤ 6mm	≤ 30mm	≤ 60mm	≤ 120mm	≤ 400mm	≤ 1000mm
	± 3°	± 0.3mm	± 0.5mm	± 0.7mm	± 1.5mm	± 5mm

DESIGNATION DESCRIPTION	NUMERO DE PROJET PROJECT NUMBER	MASSE TOTALE TOTAL MASS (g)
T50RIAHC1TICR	GPN 20-2244	4.8

Revision Level		Revision Record		The copyright of this drawing is reserved by HellermannTyton.	Drawn	Date (YYYY/MM/DD)	Title	Scale
Drawing	State	Part	MODIFIED TITLE		D.Nampon	2020/12/22		T50RIAHC1TICR
02.1	En cours de traitement	00.0		Approved	2020/12/22		Global Project Number	
	Changed			P.Cherdo	2020/12/22		20-2244	
	D.Nampon	2021/11/22					Format	
	Approved	2021/11/22					A2	
	P.Cherdo	2021/11/22					Sheet	
							1/1	

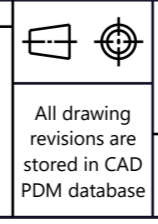

**HellermannTyton**  
www.HellermannTyton.com

Drawing-No  
**20-2244-001-CSF**