



Fixing Elements for Tubes and Harnesses with Automatic Locking Feature, connectable

IAHC-Series, Connectable

Offering a simple and secure method of attaching cables to panels. Originally designed for the automotive industry, these products are used in a wide range of applications with sheet metal panels across various industries.

Features and benefits

- Push and click closure
- Coupling elements of the IAHC variants allow parts to connect
- Clip is clicked into a specific hole
- IAHC(T) can only be connected with another IAHC element



IAHC(J)AH in combination with an IAHC(T).

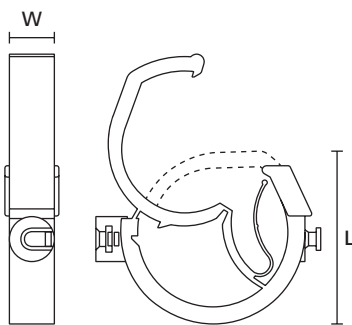

IAHC(T)

TYPE	Drawing	Bundle Ø max.	Width (W)	Length (L)	Material	Colour	Article-No.
IAHC1T		13.0	10.0	23.0	PA66HIRHS	Black (BK)	151-00223
IAHC2T		20.0	10.0	30.0	PA66HIRHS	Black (BK)	151-00199
IAHC3T		28.0	10.0	40.0	PA66HIRHS	Black (BK)	151-00213
IAHC4T		36.0	13.5	47.0	PA66HIRHS	Black (BK)	151-00207
IAHC5T		45.0	13.5	57.0	PA66HIRHS	Black (BK)	151-00195

All dimensions in mm. Subject to technical changes.

Material Specification Overview

MATERIAL	Material Shortcut	Operating Temperature	Colour**	Flammability	Material Properties*	Material Specifications
Aluminium alloy	AL	-40 °C to +180 °C	Natural (NA)		<ul style="list-style-type: none"> Corrosion resistant Antimagnetic 	RoHS
Chloroprene rubber	CR	-20 °C to +80 °C	Black (BK)		<ul style="list-style-type: none"> Weather resistant High yield strength 	RoHS
Ethylene Tetrafluoroethylene (Tefzel®)	E/TFE	-80 °C to +170 °C	Blue (BU)	UL 94 V0	<ul style="list-style-type: none"> Resistance to radioactivity UV resistant, not moisture sensitive Good chemical resistance to acids, bases, oxidizing agents 	RoHS
Polyacetal	POM	-40 °C to +90 °C, (+110 °C, 500 h)	Natural (NA)	UL 94 HB	<ul style="list-style-type: none"> Limited brittleness sensitivity Flexible at low temperature Not moisture sensitive Robust on impact 	RoHS
Polyamide 11	PA11	-40 °C to +85 °C, (+105 °C, 500 h)	Black (BK)	UL 94 HB	<ul style="list-style-type: none"> Bio-plastic, derived from vegetable oil Strong impact resistance at low temperature Very low moisture absorption Weather resistant Good chemical resistance 	HF RoHS
Polyamide 12	PA12	-40 °C to +85 °C, (+105 °C, 500 h)	Black (BK)	UL 94 HB	<ul style="list-style-type: none"> Good chemical resistance to acids, bases, oxidizing agents UV resistant 	HF RoHS
Polyamide 4.6	PA46	-40 °C to +130 °C, (+150 °C, 5000 h; +195 °C, 500 h)	Natural (NA), Grey (GY)	UL 94 V2	<ul style="list-style-type: none"> Resistance to high temperatures Very moisture sensitive Low smoke sensitivity 	HF LFH RoHS
Polyamide 6	PA6	-40 °C to +80 °C	Black (BK)	UL 94 V2	<ul style="list-style-type: none"> High yield strength 	RoHS
Polyamide 6 high impact modified	PA6HIR	-40 °C to +80 °C	Black (BK)	UL 94 HB	<ul style="list-style-type: none"> Limited brittleness sensitivity Higher flexibility at low temperature 	RoHS
Polyamide 6.6	PA66	-40 °C to +85 °C, (+105 °C, 500 h)	Black (BK), Natural (NA)	UL 94 V2	<ul style="list-style-type: none"> High yield strength 	HF RoHS
Polyamide 6.6 glass-fibre reinforced	PA66GF13, PA66GF15	-40 °C to +105 °C	Black (BK)	UL 94 HB	<ul style="list-style-type: none"> Good resistance to lubricants, fuels, salt water and solvents 	HF RoHS
Polyamide 6.6 heat and UV stabilised	PA66HSW	-40 °C to +105 °C	Black (BK)	UL 94 V2	<ul style="list-style-type: none"> High yield strength Modified elevated maximum temperature UV resistant 	HF RoHS
Polyamide 6.6 heat stabilised	PA66HS	-40 °C to +105 °C	Black (BK), Natural (NA)	UL 94 V2	<ul style="list-style-type: none"> High yield strength Modified elevated maximum temperature 	HF RoHS
Polyamide 6.6 high impact modified	PA66HIR	-40 °C to +80 °C, (+105 °C, 500 h)	Black (BK)	UL 94 HB	<ul style="list-style-type: none"> Limited brittleness sensitivity Higher flexibility at low temperature 	RoHS
Polyamide 6.6 high impact modified, heat and UV stabilised	PA66HIRHSW	-40 °C to +110 °C	Black (BK)	UL 94 HB	<ul style="list-style-type: none"> Limited brittleness sensitivity Higher flexibility at low temperature Modified elevated maximum temperature High yield strength, UV resistant 	RoHS
Polyamide 6.6 high impact modified, heat stabilised	PA66HIRHS	-40 °C to +105 °C	Black (BK)	UL 94 HB	<ul style="list-style-type: none"> Limited brittleness sensitivity Higher flexibility at low temperature Modified elevated maximum temperature 	RoHS
Polyamide 6.6 high impact modified, scan black	PA66HIR(S)	-40 °C to +80 °C, (+105 °C, 500 h)	Black (BK)	UL 94 HB	<ul style="list-style-type: none"> Limited brittleness sensitivity Higher flexibility at low temperature 	RoHS
Polyamide 6.6 UV resistant	PA66W	-40 °C to +85 °C, (+105 °C, 500 h)	Black (BK)	UL 94 V2	<ul style="list-style-type: none"> High yield strength UV resistant 	HF RoHS

MATERIAL	Material Shortcut	Operating Temperature	Colour**	Flammability	Material Properties*	Material Specifications
Polyamide 6.6 with metal particles	PA66MP	-40 °C to +85 °C, (+105 °C, 500 h)	Blue (BU)	UL 94 HB	<ul style="list-style-type: none"> High yield strength Metal and X-Ray detectable 	HF RoHS
Polyamide 6.6 with metal particles	PA66MP+	-40 °C to +85 °C	Blue (BU)	not flame retardant	<ul style="list-style-type: none"> High yield strength Metal and X-Ray detectable 	HF RoHS
Polyamide 6.6 V0	PA66V0	-40 °C to +85 °C	White (WH)	UL 94 V0	<ul style="list-style-type: none"> High yield strength Low smoke emission 	HF LFH RoHS
Polyester	SP	-50 °C to +150 °C	Black (BK)		<ul style="list-style-type: none"> UV resistant Good chemical resistance to most acids, bases and oils 	HF LFH RoHS
Polyetheretherketone	PEEK	-55 °C to +240 °C	Beige (BGE)	UL 94 V0	<ul style="list-style-type: none"> Resistance to radioactivity Not moisture sensitive Good chemical resistance to acids, bases, oxidising agents 	HF LFH RoHS
Polyethylene	PE	-40 °C to +50 °C	Black (BK), Grey (GY)	UL 94 HB	<ul style="list-style-type: none"> Low moisture absorption Good chemical resistance to most acids, bases, alcohol, oils 	HF RoHS
Polyolefin	PO	-40 °C to +90 °C	Black (BK)	UL 94 V0	<ul style="list-style-type: none"> Low smoke emissions 	HF LFH RoHS
Polypropylene	PP	-40 °C to +115 °C	Black (BK), Natural (NA)	UL 94 HB	<ul style="list-style-type: none"> Floats in water Moderate yield strength Good chemical resistance to acids, bases and solvents 	HF RoHS
Polypropylene, Ethylene Propylene Diene Terpolymer rubber free of Nitrosamine	PP, EPDM	-20 °C to +95 °C	Black (BK)	UL 94 HB	<ul style="list-style-type: none"> Good resistance to high temperature Good chemical and abrasion resistance 	HF RoHS
Polypropylene with metal particles	PPMP	-40 °C to +115 °C	Blue (BU)	UL 94 HB	<ul style="list-style-type: none"> Metal and X-Ray detectable Heat resistant Moderate yield strength Good chemical resistance 	RoHS
Polypropylene with metal particles	PPMP+	-40 °C to +85 °C	Blue (BU)	not flame retardant	<ul style="list-style-type: none"> High yield strength Metal and X-Ray detectable 	HF RoHS
Polyvinylchloride	PVC	-10 °C to +70 °C	Black (BK), Natural (NA)	UL 94 V0	<ul style="list-style-type: none"> Low moisture absorption Good chemical resistance to acids, bases, salts, alcohol, oils 	RoHS
Stainless Steel, Stainless Steel	SS304, SS316	-80 °C to +538 °C	Natural (NA)	Non burning	<ul style="list-style-type: none"> Corrosion resistant Antimagnetic Weather resistant Chemical resistance SS316 also resistant against seawater, salt spray and anorganic acids 	HF LFH RoHS
Thermoplastic Polyurethane	TPU	-40 °C to +85 °C	Black (BK)	UL 94 HB	<ul style="list-style-type: none"> High elasticity Good chemical resistance to acids, bases and oxidising agents 	HF RoHS

Tefzel® is a registered trademark of DuPont. General linguistic usage for cable ties made from raw material E/TFE is Tefzel®-Tie. In addition to Tefzel® from DuPont HellermannTyton also uses equivalent E/TFE raw material from other suppliers.

*These details are only guide values. They should not be regarded as a exhaustive material specification and are no substitute for suitability tests. Please see our datasheets for further details.

**Further colours available on request.



= Minimum Loop Tensile Strength for Cable Ties (Newton)

HF = Halogenfree

LFH = Limited Fire Hazard

RoHS = Restriction of Hazardous Substances