

SW2015

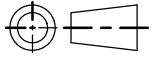

Revision level			Revision Record	Changed	Date	Approved	Date
Drawing	State	Part					
10.1	Design Release		SEE ECN# 014011	CTF	08/15/17	JPG	08/15/17

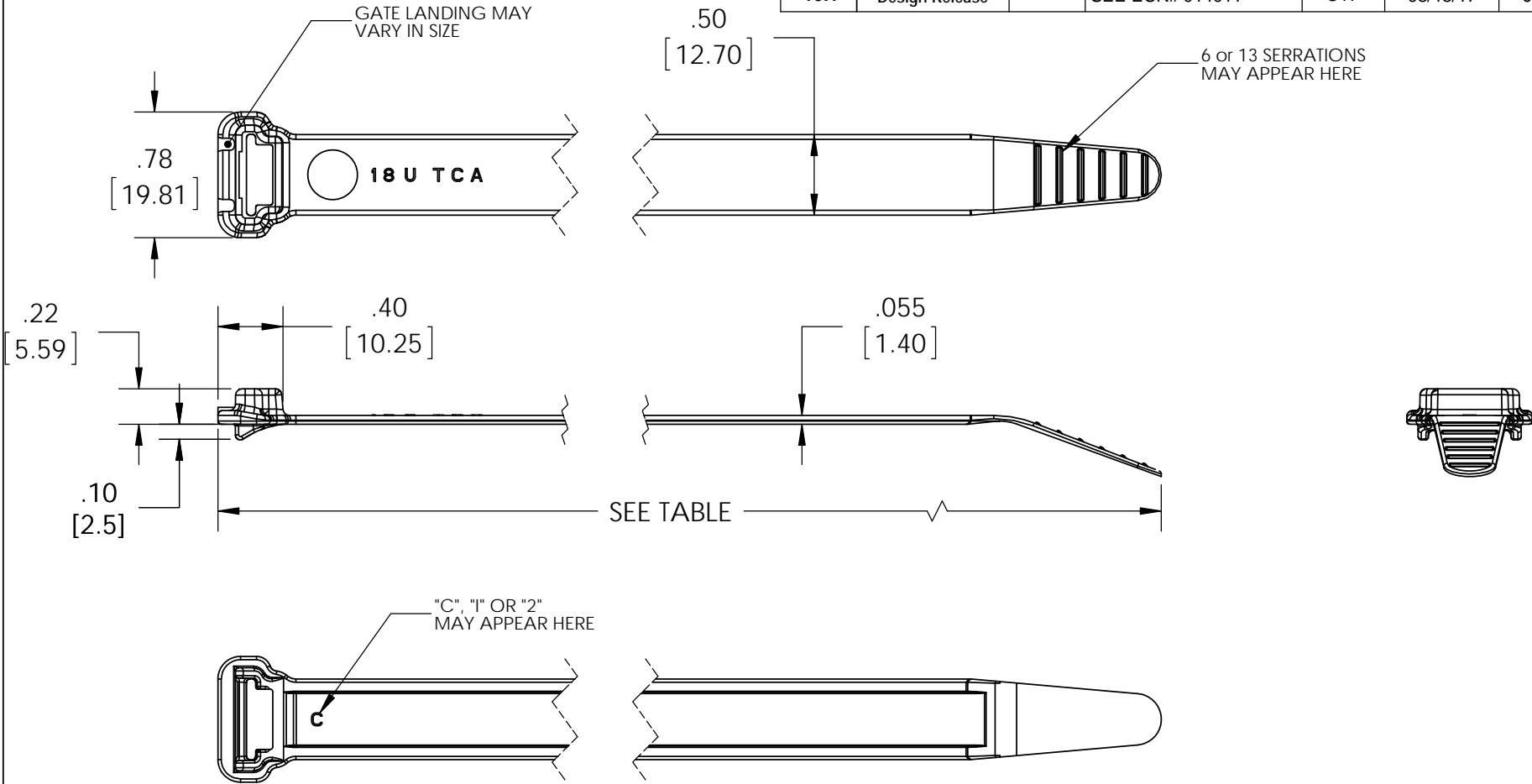

"C", "1" OR "2" MAY APPEAR HERE



FEATURES:

- WIDE STRAP TO MINIMIZE PINCHING OF SOFT HOSES AND CONVOLUTED TUBING
- LOW PROFILE HEAD
- CLAMPING RAILS TO INCREASE CIRCUMFERENTIAL GRIP ON ROUND BUNDLES
- WIDE VARIATIONS OF BUNDLE DIAMETERS .375 MINIMUM - MAXIMUM (SEE TABLE)
- THIN/FLEXIBLE STRAP TIGHTENS EASILY ON SMALLER BUNDLE DIAMETERS
- 120LB MIN LOOP TENSILE STRENGTH
- COMPATIBLE WITH THE EQUIPMENT MOUNTS

TYPE	OVERALL LENGTH ±0.3 in.	MAX BUNDLE DIA
WSS	9.1 [231.14]	2.25 [57.15]
WSI	12.1 [307.34]	3.25 [82.55]
WSR	15.1 [383.54]	4.125 [104.78]

Material PA66IMHSUV PA46	Units: inches Dimension without tolerances details to: .XXXX = ±.0005 .XXX = ±.005 .XX = ±.01 .X = ±.03 None = ±.06 ∠ = ±0.5° Dimension Formatted in [mm]	The copyright of this drawing is reserved by HellermannTyton. It is issued on condition that it is not reproduced, copied, or disclosed to a third party, either wholly or in part, without the consent of HellermannTyton.	Drawn	GGG	08/29/02	Article/Type-No SEE CHART	Scale 1:1	
			Approved	KAC	08/29/02			
			<p>North America Email: corp@htamericas.com Web: www.hellermann.tyton.com</p>			Title	T120 WIDE STRAP NON-RELEASABLE	Project Number PRP 2127004
						Drawing-No		
						CT2127004CST		Sheet 1/1